

GS-705 SHEAR LOCK

Features:

- **Powerful shear force provides highly security.**
- **Compatible with double swinging doors.**
- **With only 30mm width, the Lock and the Armature Plate can be mounted into average narrow door frames.**
- **Optional SMB-001 brackets for surface mount installation.**
- **Horizontal or vertical installation.**
- **Anti-Residual magnetism designed.**
- **Power input 12 to 28 VDC (self-regulating) .**

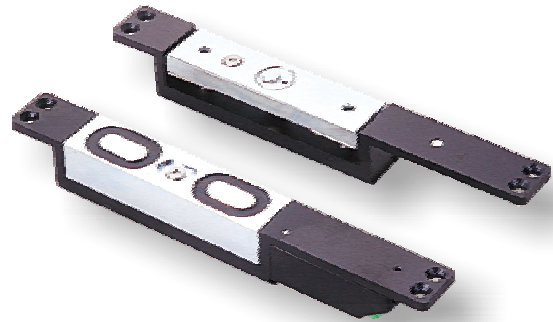

Statement:

Our Shear Locks provide up to 2700 pounds shearing force and fully concealed flush mounting in aluminum, wood and steel doors, combine the best in failsafe performance with the most advanced features in shear lock design. Concealed lock mounting is an important feature, enhancing aesthetic appearance. Standard built-in field adjustable automatic relock switch with a 1 to 6 second relock time delay.

The GS-705 series are available in two models, GS-705-30 and GS-705-35. The models may be fitted in either aluminum, wood, steel or exit doors with the assistance of SMB-001 bracket. This manual gives a guide to all of the above applications and other useful installation information.

Specifications:

- Voltage Tolerance: $\pm 10\%$
- Current Draw:
Pull in: 1.8A, Holding: 0.5A@12V DC
Pull in: 1.0A, Holding: 0.35A@24V DC
(at temperature 20°C)
- Magnetic bond sensor monitor output (SPDT rated 1A@30VDC), indicates the door locked or unlocked.
- Operating Temperature: -30~+55°C
- Humidity: 0~95% non-condensing.
- Lock's surface Temperature (when the power is on):
 \leq current temperature +20°C
- Holding Force: Up to 2700 lbs (1226 Kg) in shear.
- Locking time delay: 1~6 seconds adjustable
- Door Gap (Between the Lock and Armature plate):
3mm (1/8") maximum
- Special Finishes for magnet and armature plate: Zinc
- Housing: Black powder coated
- Epoxy Potting Compound: E87252 (S), UL94V-0
- Weight (Approx.) :
GS-705-35: 2.2 Kg
GS-705-30: 1.8 Kg

Flush Installation

Horizontal Installation

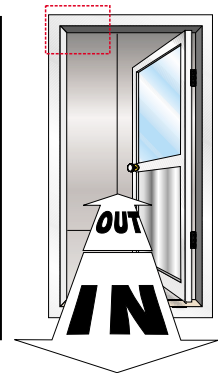
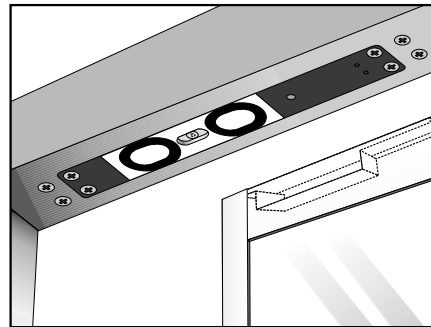

Vertical Installation

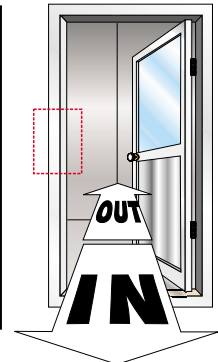
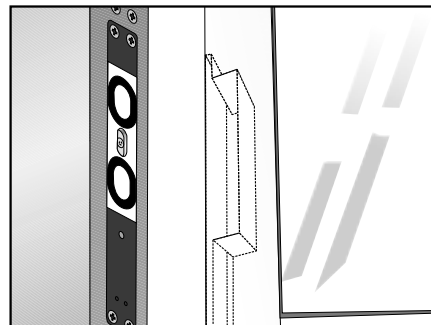

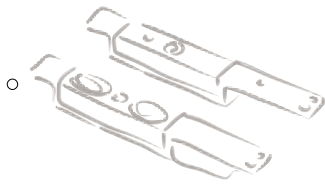

GS-705 SHEAR LOCK

Dimension:

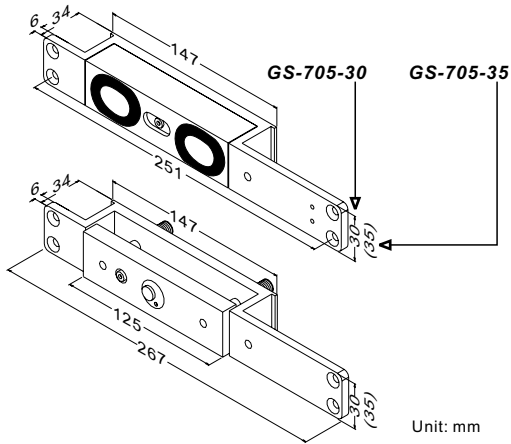

Semi-Flush Installation

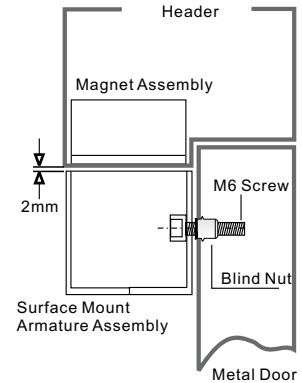
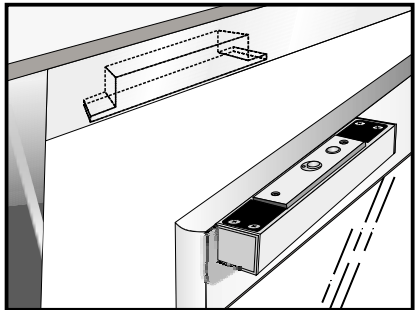

Optional Brackets:

The GS-705-35 may also be fitted semi-flush or surface installation with the use of the SMB-001 Brackets. The magnet should be fitted to the door transom and the housing holding the armature on to the door. It is vital that a minimum gap of 3mm exists between the magnet and the armature, to allow correct operation.

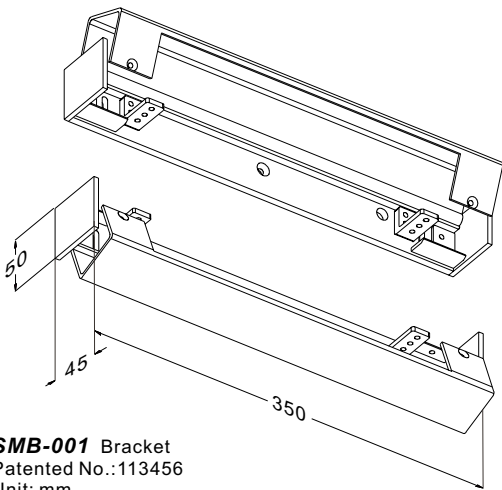

Surface Installation

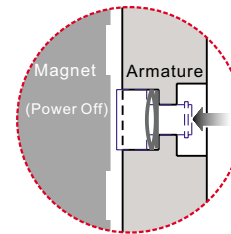
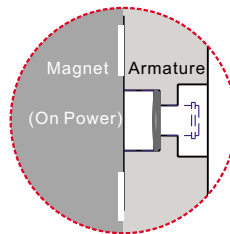
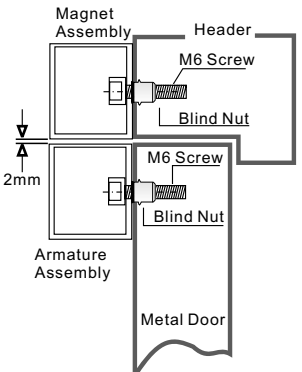
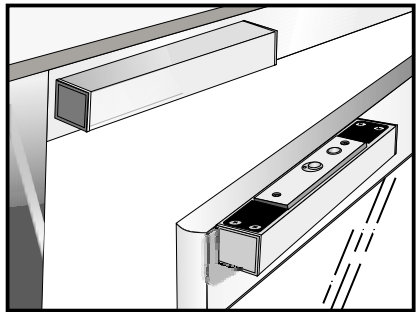

Warranty:

Our shear Locks are warranted against defects in material and workmanship while used in normal service for a period of 5 years from the date of sale to the original customer.

Disclaimer:

The information and specifications printed in this manual are current at the time of publication. The policy is one of continual development and improvement; therefore we reserves the right to change specifications without notice.

Unique Anti-Residual design

When there is no power, there will be no holding force, and the Push-off button inside the Armature Plate will pop out immediately to release the Electromagnetic Lock and the Armature Plate. The instant release circuit function will prevent residual magnetism between Electromagnetic Lock and the Armature Plate.